

IW-25-2 Dehumidifier Installation & Operations Manual

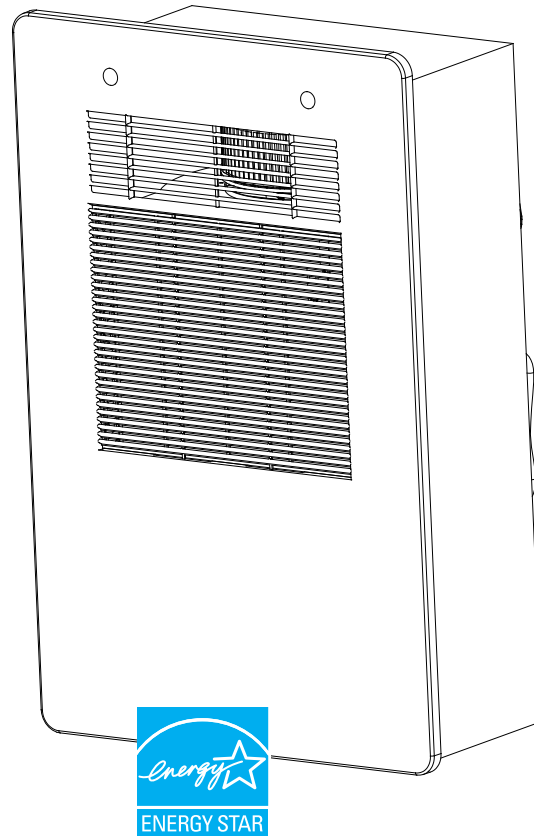

Please Read and Save These Instructions



Innovative Dehumidifier Systems, LLC

6260 Ocean Highway 17 West

Ocean Isle Beach, NC 28469

910-579-DEHU

910-579-3348

www.innovativedehumidifer.com

Table of Contents

| | |
|------------------------|---|
| Safety Notes | 2 |
| Identification | 3 |
| Electrical Supply | 3 |
| Principle of Operation | 3 |
| Installation | 4 |
| Operating Instructions | 4 |
| Diagram | 5 |
| Maintenance | 6 |
| Troubleshooting | 8 |
| Warranty Information | 9 |

Safety Notes

- The IW-25-2 Dehumidifier must always be connected using a grounded electrical connection (as required for all electrical appliances). If non-grounded wiring is used, all liability reverts to owner and the warranty is voided.
- The IW-25-2 Dehumidifier should only be installed and serviced by a qualified technician.
- If there is a chance that water flooded the dehumidifier, it should be opened and allowed to dry thoroughly before reconnecting to electrical power and restarting.
- To ensure proper operation, no obstruction should be located within 36" of the discharge of the unit.
- Do not insert any objects or fingers into the inlet or discharge. If service is required, call a qualified technician.
- All work on the dehumidifier should be done with the unit "off" and unplugged or the breaker turned off.
- Do not use water to clean the exterior. To clean unit, unplug from power, then use a damp cloth to wipe exterior.
- Drain hose must be installed to ensure proper gravity flow of condensate water to a drain source

Identification

For future reference, write down the model, serial number, and date of purchase for your dehumidifier. This is extremely helpful if you need to seek assistance in the future. The data label on the side of your unit has key characteristics of your specific unit.

Model Number: IW-25-2

Serial Number: _____ **Date of Purchase:** _____

For additional questions concerning your dehumidifier, the following options are available:

- Contact your installing contractor
- Call Innovative Dehumidifier Systems @ (910) 579-3348

Electrical Supply

Power Supply: 115 V, 60 Hz AC, Single Phase

Outlet Requirement: 3-Prong, GFI

Circuit Protector: 15 Amp Time Delay Fuse or Circuit Breaker

WARNING: 115 Volts AC may cause serious injury from electric shock.

To ensure safety:

1. Disconnect electrical power before servicing
2. Only plug unit into grounded electrical circuit
3. Do not use extension cord
4. Do not use a plug adapter.

Principle of Operation

The IW-25-2 Dehumidifier utilizes its integral humidistat to monitor the conditioned space. When the relative humidity goes above the selected set point, the dehumidifier will energize. Air is drawn across an evaporator coil, which is cooler than the dew point of air. This means moisture will condense out of the air. The air is then reheated through the condenser coil and distributed back into the room.

Control Board

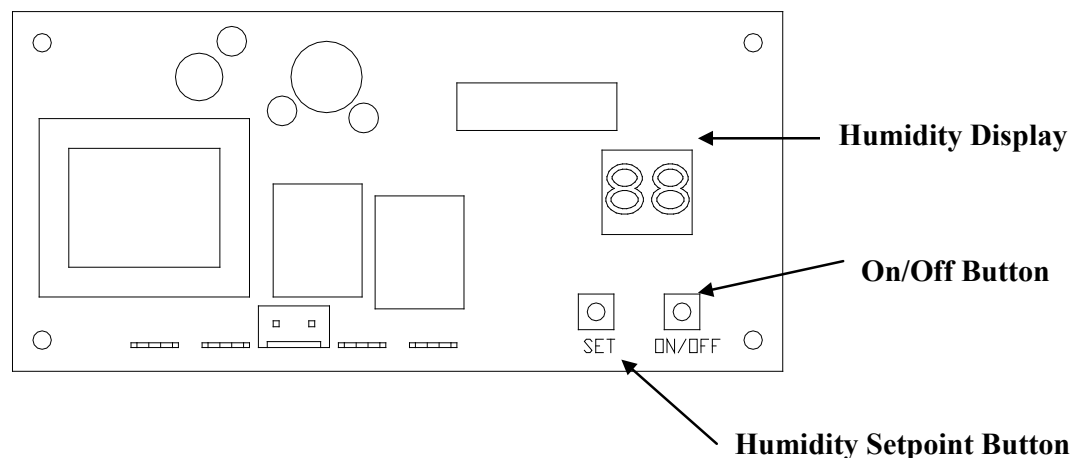

Installation

WARNING: Do not install your dehumidifier in a corrosive environment.

Mounting:

The IW-25-2 Dehumidifier is designed to mount into the wall cavity between two studs mounted on standard 16" centers. The chassis of the unit slips into the wall from the front and is secured by the four mounting tabs with screws (not provided). **Ensure the bottom of the unit is properly supported before screwing into drywall.**

Plumbing:

The 10' drain line (included) is to be attached to the barbed drain hose connection on the rear of the unit. Secure hose with a hose clamp (included). The entire length of drain line to the gravity drain must be downhill. **No low spots or dip are permitted as they may cause leaks.** It is possible to use a short piece of the included tube to deposit condensate directly into a PVC gravity drain system. **All state and local plumbing codes must be adhered to for proper operation of the unit and to maintain warranty compliance.**

Optional Condensate Pump:

If desired, condensate from the unit can be drained into a remote condensate pump (provided in end-use). If the condensate pump has a normally open safety switch, the safety switch can be connected to the dehumidifier. This will allow the safety switch to shut off the dehumidifier if it detects a problem. The wiring connections for the remote condensate pump are located on the left hand side of the electrical compartment on the back of the dehumidifier. Connect the red and black wires on the dehumidifier to the Normally Open Pump Safety switch.

Optional NO contacts for safety switch on condensate pump (NIC)

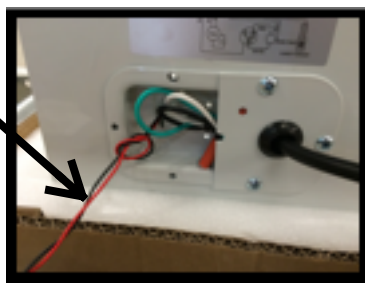

Hose Clamp to Secure Hose



Electrical:

A 10' power cord is provided for use with a standard grounded outlet. It is also possible to hard wire the unit, if necessary. Simply remove the electrical cover plate from the back of the unit, remove the cord, and connect the hard wiring. **All state and national electrical codes must be adhered to for proper unit operation and warranty compliance.**

Operating Instructions



1. ON/OFF Control ON/OFF

Plug the unit in and the display will show the current room relative humidity. Press the on/off button, and the machine will beep twice indicating it is ready for automatic service. If the humidity is below setpoint, it will remain in standby condition. If the humidity is above setpoint, the unit will turn on and begin to remove moisture from the room.

Press the on/off button again, and a single beep will indicate that the unit is turning off. No room conditioning will occur until the unit is turned on again.



2. Setting the Humidity Level SET



Press the SET button to set the indoor humidity. The humidity display  will shift from displaying the actual room humidity level to the current setpoint. The humidity can be in



5% increments from 30%-90%. Pressing the SET button increases setpoint by %5 until you reach 90%, then rolls over to 30% and increases from there.

IW-25-2 Dehumidifier Diagram

Front View

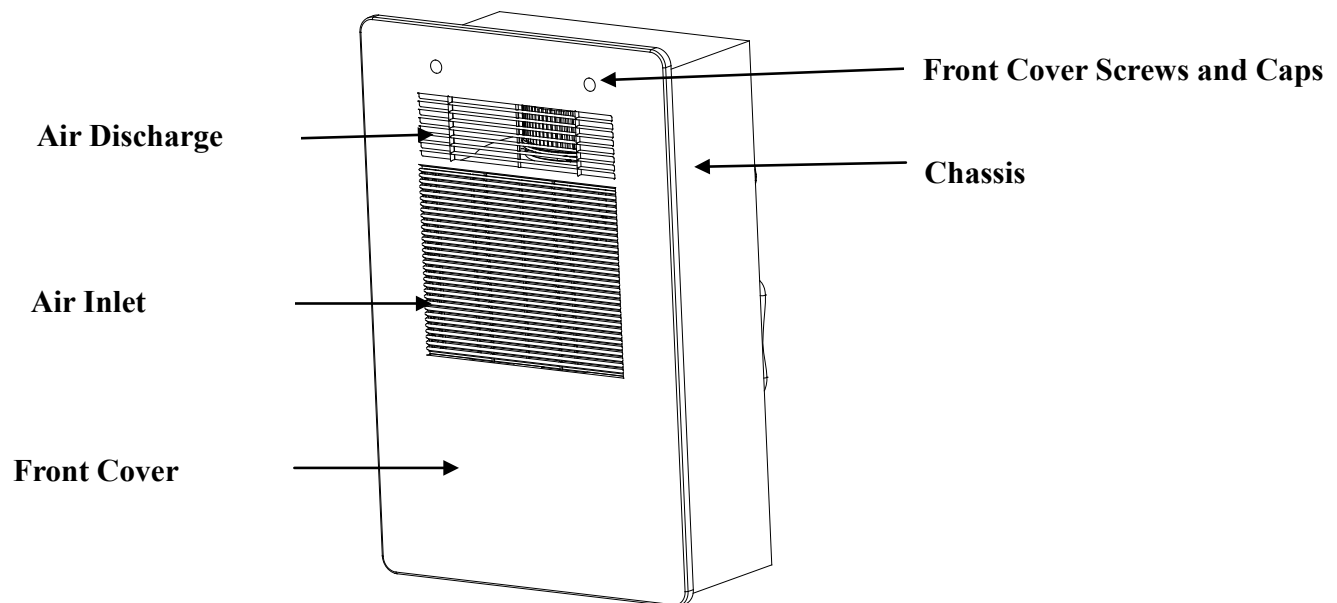

Back View

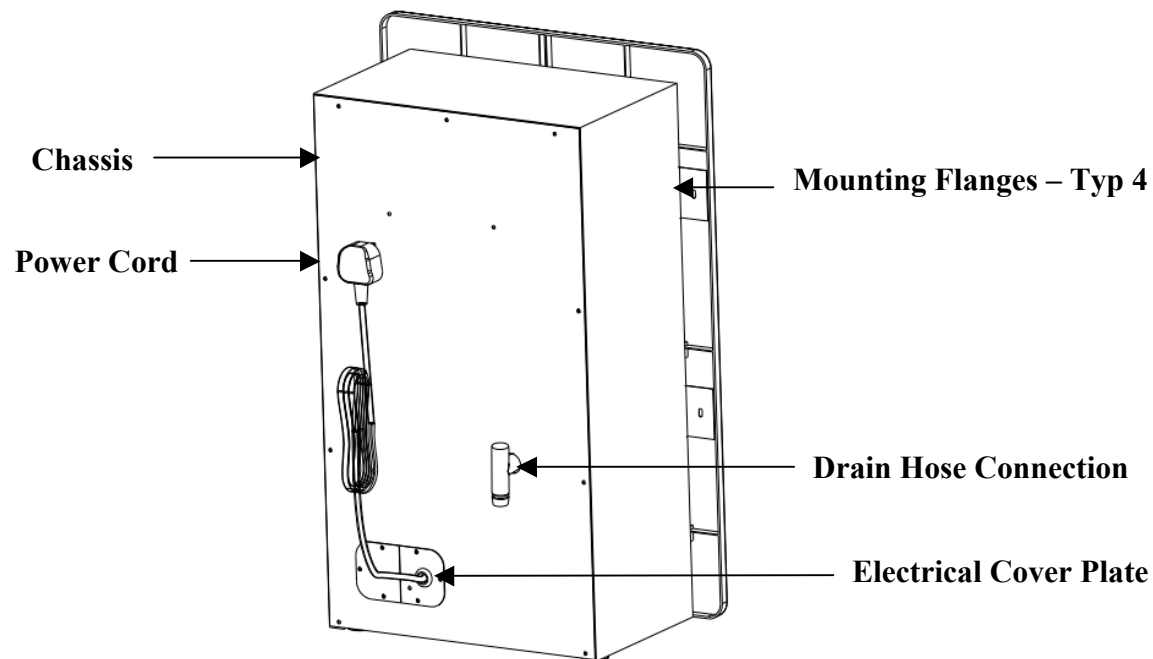

Maintenance

WARNING: 115 Volts AC may cause serious injury from electric shock. Be sure the unit is powered off and unplugged or circuit breaker is turned off before removing front cover to service unit.

Cleaning Front Cover

Use a soft damp cloth to clean the front cover as required. Do not use any soap or solvents.

Filter Maintenance

• Check the filter on a regular basis (will vary based on application). Clean or replace, as necessary

• To Remove Filter:

1. Remove screws in the front cover.
2. Push the front cover up gently to free the cover hooks from the chassis.
3. The filter is located on the back side of the front cover.

NOTE: Machine is intended to operate with all components shown. Do not remove any parts including Styrofoam fan shroud.

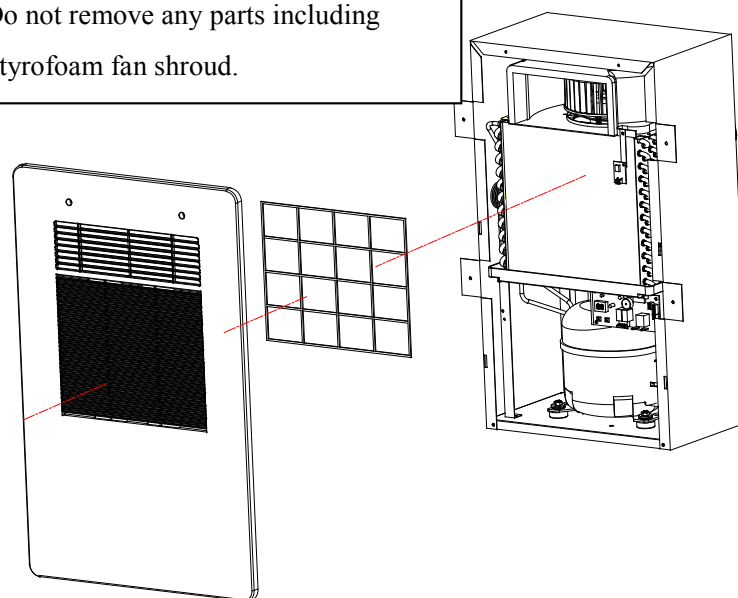

- **To Clean Filter:**

Filter can be vacuumed with a wet/dry vac or washed with warm water.

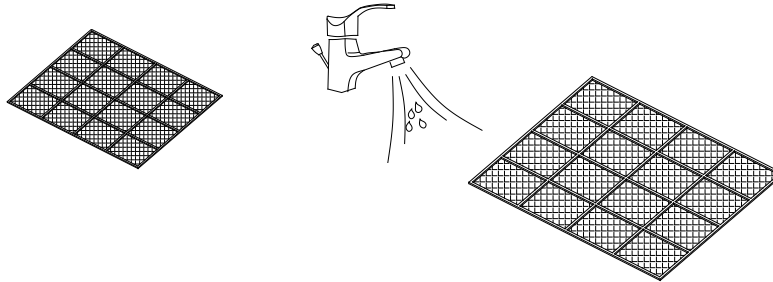

- **To Install Filter:**

1. Insert filter in tabs on top of mount
2. Flex filter to insert under bottom taps
3. Once filter is in place, reinstall front cover:
 - a. Line up cover with tabs
 - b. Slide down into place
 - c. Secure with tamperproof screws

Coil Maintenance

- Once per year, clean the coils with an approved coil cleaner
- Coil cleaner should be a self rinsing, foaming cleaner such as WEB® Coil Cleaner.

Troubleshooting

| Symptom | Cause | Solution |
|---------------------------|--|--|
| Machine Won't Run | Power Supply | Verify that there is power to the outlet and that the plug is properly installed in outlet |
| | Room Temperature Over 90°F or Below 50°F | The unit is outside the operating temperature range. Modify the room conditions so the temperature is between 50°-90°F and operation will commence. |
| Cannot Start Dehumidifier | Air Filter is Clogged | Clean the filter mesh according to instructions listed in manual. |
| | Air Inlet or Outlet is Jammed | Clear the blockage from inlet or outlet. |
| Loud Noise | Machine Is Not Level | Reposition unit so it is level |
| | Filter Mesh is Jammed | Clean the filter mesh according to instructions listed in manual. |
| | Unit not installed with 4 screws or poor quality screws | Unit MUST be installed with 4 screws provided. |
| | Machine not supported by blocking | Blocking is required |
| | Machine is touching or rubbing an unrelated item | Isolate items to eliminate noise/vibration |
| Water is Leaking | Low spots, dips, or kinks are present inside or outside machine. | <ul style="list-style-type: none"> •Ensure end of drain hose is not submerged in water from property's drain source • Re-route tubing to eliminate all low spots, kinks, valleys, and dips |
| E1 Warning Light | Sensor or Sensor Communication Issue | <ul style="list-style-type: none"> •Check sensor cable connection is secure at both ends • Replace Sensor |
| E2 Warning Light | Remote Alarm | <ul style="list-style-type: none"> •Alarm is designed to indicate that the remote condensate pump has an issue. •If pump is installed, clean or replace as necessary. •If no pump is installed, ensure the safety wires (shown on page 4) are not connected to each other |
| LO Warning Light | Sensor believes temperature is below 50°F | •If room temperature is low, raise the temperature and unit will function normally. If not, replace the sensor. |
| HI Warning Light | Sensor believes temperature is above 90°F | •If room temperature is high, lower the temperature and the unit will function properly. If not, replace the sensor |

Warranty



Innovative Dehumidifier Systems, LLC (IDS) warrants the equipment to be free from defects in workmanship and materials for a period of 24 months after shipment. This warranty is limited, however, to the repair or replacement of defective equipment. If it is necessary to return unit for service, customer is solely responsible for proper packaging, transportation costs. Customer must initiate warranty process by contacting IDS. Do not send any component or product back to IDS without Return Material Authorization.

This limited warranty does not apply to any part or component that is damaged in transit or when handling, has been subject to misuse, corrosion, chemicals, acts of God, has not been installed, operated or serviced according to the Seller's instructions, or has been operated beyond the factory-rated capacity or has been altered in any way. Routine maintenance is not covered by this warranty.

Seller's liability is limited to replacement of defective parts or components and does not include any cost of labor (including, but not limited to, labor to remove and/or reinstall any defective part), refrigerant or piping. Customer may elect to have unit fixed locally in which case required replacement parts will be sent to customer at customer's expense.

IDS shall not be responsible for loss of use of any product, loss of time, inconvenience, or damage to other equipment, or any other indirect or consequential damage with respect to property whether as a result of breach of warranty, neglect, or otherwise.

THE WARRANTIES AND LIABILITIES SET FORTH ARE IN LIEU OF ALL OTHER WARRANTIES EXPRESSED OR IMPLIED, IN LAW OR IN FACT, INCLUDING IMPLIED WARRANTIES OF MERCHANTABILITY AND FITNESS FOR PARTICULAR PURPOSE. IDS total liability, regardless of nature of claim shall not exceed original purchase price of the product. If a product or component is replaced while under warranty, the applicable warranty period shall not be extended beyond the original warranty time period.

The foregoing shall constitute the total liability of seller in the case of defective performance of all or any of the equipment or services provided to Buyer. Buyer agrees to accept and hereby accepts the foregoing as the sole and exclusive remedy for any breach or alleged breach of warranty by Seller.

